

Optimization of Diffusion Systems

A. M. Tsirlin^a and E. E. Leskov^b

^a Institute of Program Systems, Russian Academy of Sciences, Moscow, Russia

^b Moscow State University of Chemical Engineering, Staraya Basmannaya ul. 21/4, Moscow, 107884 Russia

e-mail: tsirlin@sarc.botik.ru

Received May 24, 2006

Abstract—The limiting performance of diffusion systems that convert mechanical work into separation work and extract work in systems with inhomogeneous compositions are studied. Diffusion engines with periodic and constant contact between the working body and sources are discussed.

DOI: 10.1134/S0040579507040112

The problem of deriving work from a nonequilibrium thermodynamical system and the inverse problem of maintaining its nonequilibrium state by consuming energy are central in thermodynamics. For systems that are not in equilibrium with respect to temperature, the first (direct) of the above problems is solved using heat engines and the second one (inverse) is solved using heat pumps. For systems that are not in equilibrium with respect to composition, the second problem is solved using separation systems and the first one is solved using diffusion engines. As a rule, separation systems and diffusion engines are based on membranes.

There is a lot of studies of membrane separation systems and diffusion engines in the literature [1, 2]. In the present paper, these systems will be considered using the theory of finite-time thermodynamics. The finite-time thermodynamics, which evolved in the past years, studies the limiting performance of nonequilibrium thermodynamic systems when the duration of the processes is finite and the average rate of the streams is specified [3, 4]. For example, some problems for heat engines, such as maximizing the power at given heat transfer coefficients and maximizing the efficiency at given power for different conditions of contact between the working body and surroundings, are already solved. In this case, the irreversible processes of the interaction of subsystems each of which is in internal equilibrium are considered.

For systems that are not uniform in concentration, it is most important to study the limiting performance of separation systems. In this case, however, the inverse problem of studying the performance of diffusion engines is of definite interest as well. The simplest variant of this problem was first formulated by Rosonoer [3]. The review of the literature shows that this problem was discussed rather superficially.

In the present paper, we will study the limiting performance of membrane systems in the separation pro-

cesses with fixed rates, focusing on the following problems:

(1) Minimizing the amount of energy necessary for the separation of a feed mixture with a given composition into separation products with given compositions at a given average production rate.

(2) Maximizing the power and efficiency of diffusion engines.

The solution of these problems depends strongly on whether the feed mixture used by the engine is gaseous or liquid because this determines the form of the chemical potentials of components and, hence, the driving forces of the process. For near-ideal gas mixtures, the chemical potential of component i of the mixture takes the form [5]:

$$\mu_i(T, P_i) = \mu_0(T) + RT \ln P_i, \quad i = 1, 2, \dots,$$

where P_i is the partial pressure of component i and $\mu_0(T)$ is the chemical potential of the pure component. Assuming that the ratio of the partial pressure to the total pressure is equal to x_i ,

$$P_i = P x_i = P \frac{N_i}{N}, \quad i = 1, 2, \dots$$

we can rewrite the expression for the chemical potential in the form:

$$\mu_i(T, P, x_i) = \mu_1(T, P) + RT \ln x_i, \quad (1)$$

where $\mu_1(T, P) = \mu_0(T) + RT \ln P$.

Although the chemical potential for liquids has the same form as Eq. (1), the form of the function $\mu_1(T, P)$ is different. This is caused by the fact that the chemical potential $\mu_i(T, P, x_i)$ represents the molar Gibbs energy of component i and its derivative with respect to pressure is equal to the molar volume of this component v_i [5]. In contrast to gases, the molar volume of liquids is

virtually independent of pressure and weakly dependent on temperature. As

$$\frac{\partial \mu_i}{\partial P} = \frac{\partial \mu_1}{\partial P} = v_i,$$

we obtain

$$\mu_i(T, P, x_i) = \mu_1(T) + v_i P + RT \ln x_i. \quad (2)$$

It is assumed that the processes are isothermal and the temperatures of all subsystems are equal to T . The problems listed above will be considered for gaseous mixtures and then for liquid solutions.

LIMITING PERFORMANCE OF DIFFUSION SYSTEMS FOR GASEOUS MIXTURES

Maximum Work in a Membrane Process

Consider a system consisting of a thermodynamic reservoir, the intensive variables of which are fixed and are independent of mass transfer fluxes, and a working body, the intensive variables of which can be varied with time by one or another way. The system can consume external energy or generate work. In the first case, the work will be negative; in the second, positive.

The reservoir and the working body interact through a membrane that is permeable only to one (active) component of the mixture. The mass transfer rate g depends on the chemical potentials of the active component in the reservoir μ_0 and in the working body $\mu(t)$. When these chemical potentials are equal to each other, the flux is equal to zero. In the particular case under consideration,

$$g(\mu_0, \mu) = \alpha(\mu_0 - \mu), \quad (3)$$

where α is the mass transfer coefficient. The working-body temperature T is maintained constant and equal to the reservoir temperature.

When the process duration τ and the total amount of the component G_0 transferred from the reservoir to the working body and in the reverse direction are fixed in the process characterized by a finite mass transfer coefficient, the chemical potentials μ_0 and $\mu(t)$ should differ from each other at every moment of time and the mass transfer process should be irreversible. For definiteness, we assume that $\mu_0 > \mu(0)$ and that the component is transferred from the reservoir to the working body.

The variation of the system entropy will be caused by the decrease in the reservoir entropy, the increase in the entropy of the working body, and the production of entropy due to the irreversible mass transfer σ . For a given initial state of the system (that is, the compositions of mixtures at the initial moment of time, the total

amount of the substance in the working body) and a given constant value of the quantity

$$G_0 = \int_0^\tau g[\mu_0, \mu(t)] dt \quad (4)$$

the variation of the entropies of the reservoir and working body with time τ are completely determined and the minimal increase in the system entropy corresponds to the minimum of the entropy production:

$$\bar{\sigma} = \frac{1}{T} \int_0^\tau [\mu_0 - \mu(t)] g[\mu_0, \mu(t)] dt \rightarrow \min. \quad (5)$$

In this case, the function $\mu(t)$ should be chosen.

Let us find the quantitative relationship between the work A , which can be extracted (consumed) in this process, and the value of $\bar{\sigma}$. For simplicity, we assume that the mixture in the reservoir and working body consists of two components (a more general case can similarly be considered by introducing an equivalent component). If the concentrations of the active component in the reservoir and working body are x_0 and $x(t)$, the concentrations of the second component will be equal to $1 - x_0$ and $1 - x(t)$, respectively. The variation of the substance amount G and the concentration $x(t)$ of the active component in the working body are determined by the differential equations:

$$\begin{aligned} \frac{d}{dt}(Gx) &= \frac{dG}{dt} = g(\mu_0, \mu), \quad G(0) \rightarrow \text{fix}, \\ x(0) &\rightarrow \text{fix}. \end{aligned} \quad (6)$$

As the amount of the second component is maintained constant, we obtain

$$G(0)[1 - x(0)] = [G(0) + G_0][1 - x(\tau)]. \quad (7)$$

It follows from (6) and (7) that

$$\begin{aligned} \frac{dx}{dt} &= \frac{1}{G(0)[1 - x(0)]} (1 - x)^2 g(\mu_0, \mu), \\ x(0) &\rightarrow \text{fix}. \end{aligned} \quad (8)$$

The equations for the material, energy, and entropy balances around the system take the form:

$$G_0 x_0 = G(\tau) x(\tau) - G(0) x(0), \quad (9)$$

$$G_0 h_0 - [G(\tau) h(\tau) - G(0) h(0)] = A, \quad (10)$$

$$G_0 s_0 = [G(\tau) s(\tau) - G(0) s(0)] + \bar{\sigma} = 0, \quad (11)$$

where h_0 and h , s_0 and s are the molar enthalpies and entropies of the mixture in the working body and reservoir, respectively. They are related by the equation [5]:

$$s = \frac{1}{T} \left(h - \sum_{i=1}^2 \mu_i x_i \right), \quad (12)$$

$$s_0 = \frac{1}{T} \left(h_0 - \sum_{i=1}^2 \mu_{i0} x_{i0} \right). \quad (13)$$

The pressure in the working body can vary with time, provided that $P(0) = P(\tau)$. For the chemical potentials defined by Eq. (1), the equation of entropy balance (11) in view of (10), (12), and (13) can be rewritten as

$$\begin{aligned} A/T = & -\bar{\sigma} + R \{ G_0 [x_0 \ln x_0 + (1-x_0) \ln(1-x_0)] \\ & + G(0) [x(0) \ln x(0) + (1-x(0)) \ln(1-x(0))] \\ & - G(\tau) [x(\tau) \ln x(\tau) + (1-x(\tau)) \ln(1-x(\tau))] \}. \end{aligned} \quad (14)$$

The second term in the right-hand side of this equality can be calculated using G_0 , x_0 , $G(0)$, and $x(0)$. The latter ones are related through (7) and (9) to the values of $G(\tau)$ and $x(\tau)$. Let us denote the second term as $B[G_0, x_0, G(0), x(0)]$. It can be either positive or negative. It follows from equality (14) that

$$A_{\max} = T(B - \bar{\sigma}_{\min}). \quad (15)$$

The maximum of the produced (minimum of the spent) work corresponds to the minimum of entropy production in the mass transfer process.

The problem of finding the minimum of $\bar{\sigma}$ when constraint (4) is valid (or the equivalent problem for the maximum of G_0 at a given constant value of $\bar{\sigma}$) is an averaged nonlinear programming problem [6]. Unlike the problem for the constrained maximum of a function, its optimal solution can vary with time. This solution is a piecewise constant function that can take not more than two values. We will not calculate these values and the fraction of the whole process time during which $\mu^*(t)$ takes each of these values because in the most common case, where the Lagrangian function for the unaveraged problem

$$L = g[\mu_0, \mu(t)][\mu_0 - \mu(t) - \lambda]$$

is convex with respect to μ (second derivative of L with respect to μ is positive), the solution to the formulated problem is constant. Consequently, the constancy condition depends on the validity of the inequality:

$$\frac{\partial^2 g}{\partial \mu^2} (\mu_0 - \mu(t) - \lambda) - 2 \frac{\partial g}{\partial \mu} \geq 0. \quad (16)$$

The multiplier λ , which is equal to the derivative of the minimum value of $\bar{\sigma}$ with respect to G_0 , should be positive due to the physical nature of the problem. The second derivative of L with respect to μ for the mass transfer rate in the form of (3) is equal to $2\lambda\alpha$ and is known to be positive. In all cases where inequality (16) holds, the optimal value of the chemical potential of the active component for the working body is constant and determined by the equation:

$$g(\mu_0, \mu^*) = \frac{G_0}{\tau}. \quad (17)$$

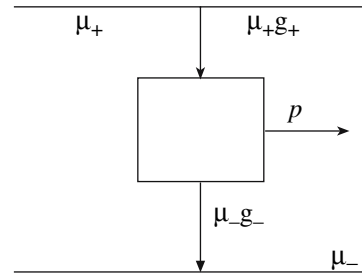

Fig. 1. Schematic diagram of a diffusion engine with a constant contact between the working body and sources.

Consequently, the chemical potential of the active component of the working body for any rate satisfying (16) should be controlled so that the mass transfer rate should be constant.

The law of variation of the control variable, such as the working-body pressure, corresponding to this solution will not be constant in time because the mixture composition is varied during the process according to Eq. (8), in which the flux is determined by Eq. (17).

For mass transfer law (3), the minimal entropy produced is $\bar{\sigma}_{\min} = G_0^2 / (\alpha\tau)$. It follows from equality (15) that positive work can be extracted from the system under study only when $\tau > \tau_{\min} = G_0^2 / (\alpha B)$. It is easy to see that the process duration τ^* , for which the average extraction rate of work $A^*(\tau)/\tau$ is maximal, is twice larger than τ_{\min} .

In the case where the system contains a source of a finite capacity at constant temperature and pressure instead of the reservoir (source of an infinite capacity), the fraction of the active component varies according to an equation similar to (8). As a result, the chemical potential μ_0 is changed. However, here also, the minimum of the entropy production for mass transfer law (3) corresponds to such variation of $\mu(t)$ that the mass transfer rate is maintained constant.

Instead of the calendar time, the problem can be studied using the time of contact, when the working body moves and its parameters at every point of the loop remain constant. This can be used to determine the optimal laws of pressure variation for the zones of contact between the working body and source.

Diffusion-Mechanical Cycle for Maximum Power. Let us consider the direct cycle of work extraction in a system consisting of a working body and two reservoirs with different chemical potentials. In the first reservoir, the chemical potential of the key element is equal to μ_+ ; in the second, μ_- ; for definiteness, $\mu_+ > \mu_-$ (Fig. 1). The process is cyclic: the increase in entropy, internal energy, and mass of the key component of the working body around the cycle is equal to zero. The temperatures are the same for all subsystems.

Alternating contact with reservoirs. Consider the case where the working body alternately contacts the

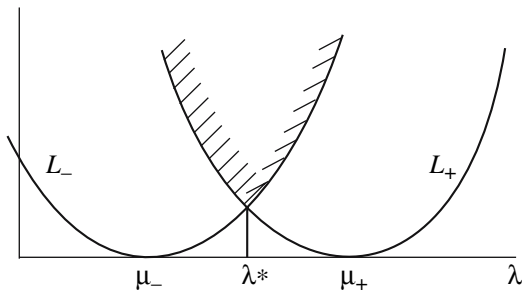

Fig. 2. Dependence of the maximum of the Lagrangian function with respect to μ on λ .

first and second reservoirs and its parameters are cyclically varied with time. Let τ stand for the cycle duration and $\mu_0(t)$ stand for the source chemical potential, which can take the values of μ_+ and μ_- . The formulation of the problem dealing with the production of maximum work A in a given time τ takes the form:

$$A = \int_0^{\tau} \mu g(\mu_0, \mu) dt \rightarrow \max_{\mu_0, \mu} \quad (18)$$

with the constraints placed on the increment in the amount of the working-body substance (cyclicality constraints):

$$\Delta G = \int_0^{\tau} g(\mu_0, \mu) dt = 0. \quad (19)$$

To calculate the basic values of μ and μ_0 in the problem given by (18) and (19), we can write the Lagrangian function and find its maximum with respect to μ_0 and μ and its minimum with respect to λ :

$$L = \{g(\mu_0, \mu)(\mu - \lambda)\} \rightarrow \max_{\mu_0, \mu} \min_{\lambda}$$

The number of basic values of μ_0 is equal to two: one of them corresponds to $\mu_0 = \mu_+$ and the other to $\mu_0 = \mu_-$. For the Lagrangian function L that is strictly convex with respect to μ , the basic values of μ satisfy the conditions:

$$\frac{\partial L}{\partial \mu} = \frac{\partial g}{\partial \mu}(\mu - \lambda) + g(\mu_0, \mu) = 0$$

or

$$\frac{g(\mu_0, \mu)}{\mu - \lambda} = -\frac{\partial g(\mu_0, \mu)}{\partial \mu}$$

The roots for this equation for $\mu_0 = \mu_+$ and $\mu_0 = \mu_-$ will be denoted by μ_1 and μ_2 , respectively. As L is maximal at the basic points, we can write

$$L(\mu_+, \mu_1, \lambda) = L(\mu_-, \mu_2, \lambda), \quad (20)$$

which determines the value of λ .

Let us specify the obtained relations for

$$g(\mu_0, \mu) = \alpha(\mu_0)(\mu_0 - \mu).$$

It follows from (20) that

$$\mu_1 = \frac{\mu_+ + \lambda}{2}, \quad \mu_2 = \frac{\mu_- + \lambda}{2}. \quad (21)$$

Substituting μ_1 and μ_2 into the function L for each basic value gives its dependence on λ :

$$L_+ = L(\mu_+, \mu_1) = \frac{\alpha_+}{4}(\mu_+ - \lambda)^2,$$

$$L_- = L(\mu_-, \mu_2) = \frac{\alpha_-}{4}(\mu_- - \lambda)^2.$$

The maximum of L with respect to μ_0 and μ reaches its minimal value with respect to λ (Fig. 2) when

$$L_+(\lambda) = L_-(\lambda) \rightarrow \lambda^* = \frac{\sqrt{\alpha_+ \mu_+} + \sqrt{\alpha_- \mu_-}}{\sqrt{\alpha_+} + \sqrt{\alpha_-}}. \quad (22)$$

The fractions of time τ of contact with reservoirs are determined by Eq. (19) and can be written as

$$\gamma_+ = \frac{\alpha_- \sqrt{\alpha_+}}{\alpha_- \sqrt{\alpha_+} + \alpha_+ \sqrt{\alpha_-}},$$

$$\gamma_- = \frac{\alpha_+ \sqrt{\alpha_-}}{\alpha_- \sqrt{\alpha_+} + \alpha_+ \sqrt{\alpha_-}}.$$

The maximal work in time τ takes the form:

$$A^*(\tau) = \tau[\gamma_+ \mu_1 \alpha_+ (\mu_+ - \mu_1) + \gamma_- \mu_2 \alpha_- (\mu_2 - \mu_-)],$$

where μ_1 and μ_2 can be determined from (21) after the value of λ from (22) is substituted into this expression. The maximal power is equal to

$$\frac{A^*(\tau)}{\tau} = [\gamma_+ \mu_1 \alpha_+ (\mu_+ - \mu_1) + \gamma_- \mu_2 \alpha_- (\mu_2 - \mu_-)].$$

Constant contact with sources. In heat engines, there can be either alternate or constant contact between the working body and sources. In the latter case, the parameters of the working body are distributed and the process in it can be regarded close to reversible if the distribution of the parameters is caused by the conductive flux. Likewise, a constant contact with sources is possible in systems that are not homogeneous in concentration, such as separation systems and diffusion engines.

In this case, the maximal power takes the form of a nonlinear programming problem:

$$P = [g_1(\mu_+, \mu_1)\mu_1 - g_2(\mu_2, \mu_-)\mu_2] \rightarrow \max_{\mu_1, \mu_2}$$

with the constraint

$$g_1(\mu_+, \mu_1) - g_2(\mu_2, \mu_-) = 0. \quad (23)$$

The optimality constraint for this problem leads to the relation:

$$\mu_1 - \mu_2 = \frac{g_2(\mu_2, \mu_-)}{\partial g_2 / \partial \mu_2} - \frac{g_1(\mu_+, \mu_1)}{\partial g_1 / \partial \mu_1}, \quad (24)$$

which together with equality (23) determines the desired variables.

Let g_1 and g_2 are proportional to the difference between the chemical potentials:

$$g_1 = \alpha_1(\mu_+ - \mu_1), \quad g_2 = \alpha_2(\mu_2 - \mu_-).$$

Equality (24) can be written in the form:

$$\mu_1 - \mu_2 = \frac{\mu_+ - \mu_-}{2}. \quad (25)$$

The constraint $g_1 = g_2$ results in

$$\alpha_1 \mu_1 + \alpha_2 \mu_2 = \alpha_1 \mu_+ + \alpha_2 \mu_-. \quad (26)$$

The solution to Eqs. (25) and (26) can be written as

$$\mu_2^* = \frac{1}{2(\alpha_1 + \alpha_2)} [\mu_+ \alpha_1 + \mu_- (\alpha_1 + 2\alpha_2)],$$

$$\mu_1^* = \frac{1}{2(\alpha_1 + \alpha_2)} [\mu_+ (\alpha_2 + 2\alpha_1) + \mu_- \alpha_2].$$

The value of maximal power corresponding to this choice is

$$p_{\max} = \frac{\bar{\alpha}}{4} (\mu_+ - \mu_-)^2,$$

where the equivalent mass transfer coefficient is defined as

$$\bar{\alpha} = \frac{\alpha_1 \alpha_2}{\alpha_1 + \alpha_2}.$$

LIMITING PERFORMANCE OF DIFFUSION SYSTEMS FOR LIQUID MIXTURES

The result obtained above for the membrane systems consisting of a working body and a source of finite or infinite capacity using gaseous mixtures can be translated in the same form to liquid solutions with allowance for the different form of the chemical potential. Diffusion engines are most often designed for the treatment of saline water. Let us consider two flow-sheets of liquid diffusion engines.

Diffusion Engine with a Constant Contact between the Working Body and the Sources. Let the system consist of two liquids with the same temperature separated by a semipermeable membrane. One of the liquids is a pure solvent and the other is a solution in which some substance of concentration C is dissolved. The membrane is permeable only to the solvent. The equilibrium in the system is reached as soon as the

chemical potentials calculated by formula (2) become equal to each other:

$$v_0 P_0 - v_r P_r = -RT \ln x_r.$$

Let the difference of pressure across the membrane be denoted as π . Also, we will keep in mind that the molar volumes v_0 and v_r for low concentrations are equal to each other. The mole fraction of the dissolved component will be denoted as x_1 . If its value is low, then $\ln x_r = \ln(1 - x_1) \approx -x_1$. In this case,

$$\pi = RT \frac{x_1}{v_0} = RTC. \quad (27)$$

Equation (27) is called the van't Hoff equation for osmotic pressure.

Consider the system shown in Fig. 3. The chamber to the left of the membrane contains a pure solvent at an environmental pressure equal to P_0 . The chamber of volume V to the right of the membrane contains a continuously replenished solution in which the concentration of the dissolved component is C . The pressure in the right chamber is P_2 and the solution is assumed to be ideal. When an equilibrium is reached in the right chamber (that is, the flux through it is equal to zero), the pressure established in it will exceed P_0 by the value of osmotic pressure π . The osmotic pressure value is related to the concentration and temperature in the chamber by the van't Hoff equation. When the solution in the chamber is replenished, the pressure $P_2 < P_0 + \pi$, giving rise to a solvent flux g across the semipermeable membrane. Conventionally, the diffusion flux is taken to be equal to the difference between the actual and equilibrium pressures:

$$g = \alpha(P_0 + \pi - P_2) = \alpha(\pi - \Delta P), \quad (28)$$

where $\Delta P = P_2 - P_0$.

Let p_1 stand for the power of the pump supplying the concentrated solution, g_1 stand for the flow rate of this solution, and C_1 stand for the solution concentration. Assuming that the pump efficiency is 100%, we obtain

$$p_1 = \Delta P g_1.$$

The additional flux across the membrane increases the volume of the solution, which drives a turbine and generates power p_2 :

$$p_2 = (g_1 + g)\Delta P.$$

Consequently, the power r and efficiency η of the saline diffusion engine can be written as

$$p = p_2 - p_1 = g\Delta P = \alpha(\pi - \Delta P)\Delta P,$$

$$\eta = \frac{p}{g_1} = \frac{\alpha(\pi - \Delta P)\Delta P}{g_1},$$

where the diffusion engine efficiency is the work extracted from 1 m³ of the concentrated solution. From

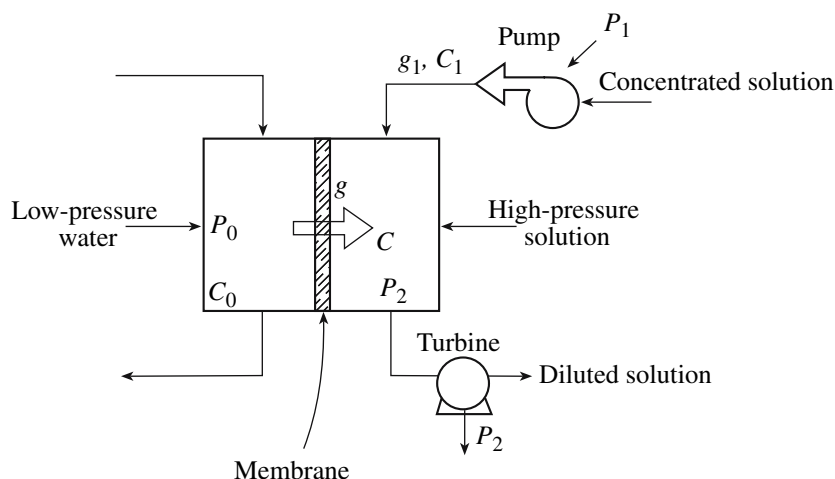

Fig. 3. Schematic diagram of a diffusion engine with a constant contact between the working body and sources.

here on, according to the accepted system of units, the units of power and efficiency referred to a unit membrane surface area are $J/(m^2 s)$ and J/m^3 , respectively. If the relationship between π and ΔP is ignored, the power reaches a maximum when $\Delta P = \pi/2$ and its upper limit is written as

$$\bar{p} = \alpha\pi^2/4 = \alpha/4(CRT)^2.$$

As $C < C_1$, the value of the power is always less than

$$\bar{p}^* = \alpha/4(C_1RT)^2, \quad (29)$$

which is the upper bound for the maximal power.

The estimate produced by Eq. (29) can be refined if we take into consideration that g , ΔP , and C are related to each other by Eq. (28) and the equation of material balance on the dissolved component

$$(g_1 + g)C = g_1C_1. \quad (30)$$

Expressing C and ΔP in terms of g from Eqs. (28) and (30) and substituting them into p and η , we obtain

$$C = \frac{g_1C_1}{g_1 + g}, \quad \Delta P = CRT - \frac{g}{\alpha}, \quad (31)$$

$$p = g\Delta P = \frac{RTC_1g_1g}{g_1 + g} - \frac{g^2}{\alpha}, \quad (32)$$

$$\eta = \frac{\alpha(\pi - \Delta P)\Delta P}{g_1} = \frac{RTC_1g}{g_1 + g} - \frac{g^2}{\alpha g_1}. \quad (33)$$

The points of maximum with respect to g for two concave functions (32) and (33) coincide. Consequently, to find the optimal value of g^* , we will use one of the functions, specifically the expression for p . The

condition for the maximum with respect to g leads to the inequality:

$$g(g_1 + g)^2 = \frac{\alpha RT g_1^2 C_1}{2}. \quad (34)$$

Equation (34) can be rewritten as

$$\frac{g^3}{g_1} + 2\frac{g^2}{g_1} + g = \frac{\alpha RTC_1}{2} \quad (35)$$

and its right-hand side can be denoted for brevity as M . Its solution will be denoted as g^* . It is obvious that it satisfies the inequality:

$$0 < g < M.$$

Numerical solution of Eq. (35) makes it possible to refine the value of the limiting power of the diffusion engine and find the corresponding operating conditions. Equation (34) determines g^* for the chosen values of g_1 and C_1 ; Eq. (31), for C^* and ΔP^* .

It should be noted that the ideal solution bounds the value of the concentration of the working solution:

$$C = C_1 \frac{g_1}{g_1 + g}.$$

The concentration should not be very high: otherwise, the molecules of the dissolved component will interact with each other and relation (27) is upset.

Diffusion Engine with an Alternate Contact between the Working Body and Sources. In the schematic diagram of the diffusion engine discussed in the preceding section, the working body was an open system working in constant contact with two sources under steady-state conditions. One of them supplied a concentrated solution and the other supplied a solvent.

Figure 4 shows the schematic diagram for a diffusion engine in which the working body alternately contacts each of the sources, receiving a solvent through

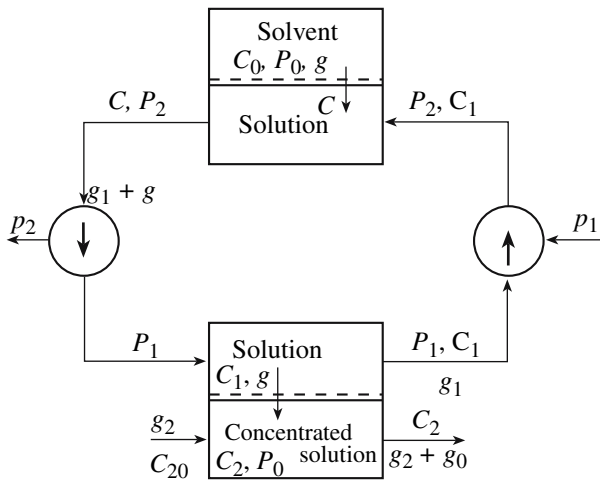

Fig. 4. Schematic diagram of a diffusion engine with an alternate contact between the working body and sources.

one membrane and giving it up to a concentrated solution through another membrane. In this case, the pressure and flow rate of the working body are periodically varied: pressure increases for a lower flow rate (power p_1 is consumed) and decreases for a higher flow rate (power p_2 is generated).

We will write the balance equations for this diagram and study its limiting performance, ignoring the energy losses for driving the flow of the concentrated solution through the bottom chamber and assuming that the concentration of the dissolved component in the g_2 flow is equal to unity and that the pressure of the surrounding medium is equal to P_0 . For simplicity, flow rates will be used instead of mole fluxes.

The engine power is

$$p = p_2 - p_1 = (g_1 + g)\Delta P_{21} - g_1\Delta P_{21} = g\Delta P_{21},$$

where $\Delta P_{21} = P_2 - P_1$.

The efficiency will be defined as the ratio of power p to the flow rate g_2 of the dissolved component:

$$h = \frac{p}{g_2} = \frac{g}{g_2}\Delta P_{21}.$$

The rate of mass transfer is determined by the relations:

$$\begin{aligned} g &= \alpha_1(P_0 + \pi - P_2) = \alpha_1(\pi - \Delta P_{20}) \\ &= \alpha_2[(P_1 + \pi_2) - (P_0 + \pi_1)] = \alpha_2(\Delta\pi_{21} + \Delta P_{10}), \end{aligned} \quad (36)$$

where $\Delta P_{20} = P_2 - P_0$, $\Delta\pi_{21} = \pi_2 - \pi_1$, $\Delta P_{10} = P_1 - P_0$. Equation (36) corresponds to the condition that the mass of the working body averaged over the cycle is constant.

Figure 5 demonstrates the cycle of the working body of this diffusion engine. The power p_1 is equal to the area of the rectangular P_2dcP_1 , and the power p_2 to the area of P_2abP_1 . The engine power p is equal to the area of the hatched rectangular $abcd$.

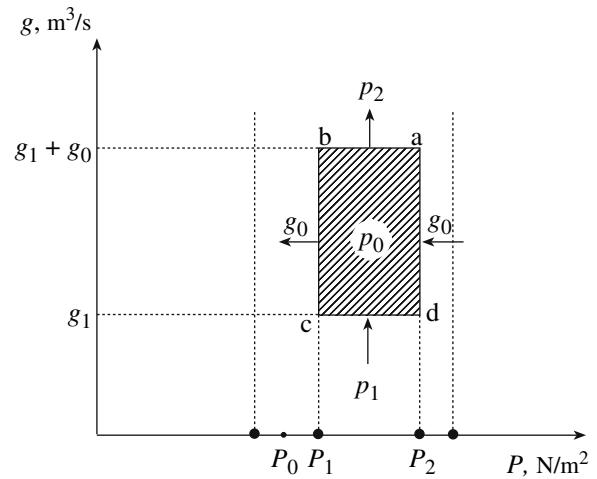

Fig. 5. Variation cycle for the parameters of the working body in a diffusion engine.

The power of the diffusion engine will be determined when the relationship between the osmotic pressures in the chambers and the flow rates is ignored. To do it, we will solve the problem of constrained optimization:

$$p = (P_2 - P_1)g \rightarrow \max_{P_1, P_2}$$

with the constraints:

$$\alpha_1(P_0 + \pi - P_2) = \alpha_2(P_1 - P_0 + \pi_2 - \pi_1) = g. \quad (37)$$

It follows from Eq. (37) that

$$P_1 = \frac{g}{\alpha_2} + P_0 + \pi_1 - \pi_2,$$

$$P_2 = P_0 + \pi - \frac{g}{\alpha_1}.$$

Let us introduce the equivalent permeability:

$$\bar{\alpha} = \frac{\alpha_1\alpha_2}{\alpha_1 + \alpha_2}$$

and write the equation:

$$P_2 - P_1 = \pi - \pi_1 + \pi_2 - \frac{g}{\alpha}.$$

Then

$$\begin{aligned} p &= g(\pi - \pi_1 + \pi_2 - \frac{g}{\alpha}) \\ &= g(\pi + \Delta\pi_{21} - \frac{g}{\alpha}) \rightarrow \max_g. \end{aligned} \quad (38)$$

The maximum of this expression, which is equal to

$$p^* = \frac{\bar{\alpha}(\pi - \pi_1 + \pi_2)^2}{4} = \frac{\alpha(\pi + \Delta\pi_{21})^2}{4},$$

is reached at

$$g^* = \frac{\bar{\alpha}(\pi - \pi_1 + \pi_2)}{2} = \frac{\alpha(\pi + \Delta\pi_{21})}{2}.$$

Keeping in mind that the osmotic pressures in the chambers are related to the concentrations by van't Hoff equation (27) and the concentrations are related to the flow rates g_1 , g_2 , and g , we obtain

$$\pi = CRT = C_1 \frac{g_1 RT}{g_1 + g},$$

$$\Delta\pi_{21} = (C_2 - C_1)RT = \left(\frac{g_2 C_{20} + g C_1}{g_2 + g} - C_1 \right) RT.$$

In view of these relations, expression (38) for the engine power takes the form:

$$p = g \left[RT \left(\frac{C_1 g_1}{g_1 + g} + \frac{g_2 C_{20} + g C_1}{g_2 + g} - C_1 \right) - \frac{g}{\bar{\alpha}} \right] \quad (39)$$

$$= g \left[RT \left(\frac{g_2 C_{20} + g C_1}{g_2 + g} - \frac{C_1 g}{g_1 + g} \right) - \frac{g}{\bar{\alpha}} \right] \rightarrow \max_g.$$

The expression for the efficiency is written as

$$\eta = \frac{g}{g_2} \left[RT \left(\frac{g_2 C_{20} + g C_1}{g_2 + g} - \frac{C_1 g}{g_1 + g} \right) - \frac{g}{\bar{\alpha}} \right] \rightarrow \max_g. \quad (40)$$

The points of maximum with respect to g for the criteria (39) and (40) coincide. Therefore, we can use either of them in the conditions of optimality to find g^* . The stationarity condition of p with respect to g leads to an equation for the optimal flow rate:

$$g = \frac{\bar{\alpha} RT}{2} \left[\left(\frac{g_2^2 C_{20} + 2g g_2 C_1 + g^2 C_1}{(g_2 + g)^2} \right) - C_1 \frac{g(g + 2g_1)}{(g_1 + g)^2} \right]. \quad (41)$$

The solution to Eq. (41) will be g^* : it is the optimal value of flow rate g at which the efficiency η and power p take their maximal values. The values of flow rate g^* depends on the values of g_1 , g_2 , and C_1 . Its substitution into the equations for p and η determines the maximal power $p^*(g_1, g_2, C_1)$ and efficiency $\eta^*(g_1, g_2, C_1)$. The nonnegative nature of p^* and η^* imposes constraints on the possible values of g_1 , g_2 , and C_1 . For example, increasing g_1 and g_2 or decreasing C_1 causes an increase in p^* .

CONCLUSION

The estimates obtained in the present paper for the limiting performance of diffusion engines can be used to making their reversible-thermodynamics analysis more accurate and consider the influence of the kinetic factors (mass transfer relations, membrane permeabilities)

and production flow rate. These estimates can also be used for the optimization of more complex membrane systems. The capacity of membrane systems increases in proportion to the membrane permeability. In this case, the performance of membranes is decreased by the nonuniformity of concentrations in the solution, polarization phenomena, and the other factors ignored in obtaining the above estimates.

NOTATION

A —work, J;
 C —component concentration, mol/m³;
 g —mole flux (flow rate), mol/s;
 G —mixture amount, mol;
 h —molar enthalpy, J/mol;
 L —Lagrangian function;
 P —pressure, Pa;
 p —power, J/s;
 R —universal gas constant, J/(mol K);
 s —molar entropy, J/(mol K);
 t —current time, s;
 T —temperature, K;
 V —volume, m³;
 x —mole fraction of a component in mixture, mol/mol;
 α —mass transfer coefficient, m⁵/(H m² s);
 γ —fraction of cycle duration τ ;
 η —diffusion engine efficiency, J/m³;
 λ —Lagrangian multiplier;
 μ —chemical potential, J/mol;
 π —osmotic pressure, N/m²;
 σ —entropy production, J/(s K);
 τ —process duration, s;
 v —molar volume, m³/mol;
 0 —initial moment of time.

SUBSCRIPTS AND SUPERSSCRIPTS

i —component;
 0 —variables of thermodynamic reservoir or pure solvent;
 \int —integral value of a quantity or upper limit;
 $*$ —optimal value of a variable;
 r —solution.

REFERENCES

1. Brock, T.D. *Membrane Filtration. A User's Guide and Reference Manual*, Heidelberg: Seiten-Springer, 1983. Translated under the title *Membrannaya fil'tratsiya*, Moscow: Mir, 1987.

2. Dubyaga, V. P.; Perepechkin, L. P.; Katalievskii, E. E. *Polimernye membrany* (Polymer Membranes), Moscow: Khimiya, 1981.
3. Rozonoer, L.I., Optimal Thermodynamic Processes with Chemical Reaction and Diffusion, in *Termodinamika i regulyatsiya biologicheskikh protsessov* (Thermodynamics and Regulation of Biological processes), Moscow: Nauka, 1984.
4. Orlov, V.N. and Rudenko, A.V., Optimal Control in Problems of the Limiting Performance of Irreversible Thermodynamic Processes, *Avtom. Telemekh.*, 1985, no. 5, pp. 27–41.
5. Prigogine, I. and Defay, R., *Chemical Thermodynamics*, London: Longmans Green, 1954. Translated under the title *Khimicheskaya termodinamika*, Moscow: Nauka, 1966.
6. Tsirlin, A.M., *Metody usrednennoi optimizatsii i ikh prilozheniya* (Methods of Averaged Optimization and Their Applications), Moscow: Fizmatlit, 1997.
7. Andresen, B., *Finite-Time Thermodynamics*. Copenhagen: Univers, 1983.
8. Tsirlin, A.M., *Neobratimye otsenki predel'nykh vozmozhnostei termodinamicheskikh i mikroekonomicheskikh sistem* (Irreversible-Thermodynamics Estimates of the Limiting Performance of Thermodynamic and Microeconomic Systems), Moscow: Nauka, 2003.
9. Salamon, P. and Nitzan, A., Finite Time Optimizations of a Newton's Law Carnot Cycle, *J. Chem. Phys.*, 1981, vol. 20, no. 1, p. 51.